

Strada Led 1



(I)

Apparecchio per illuminazione stradale a Led, in alluminio.
 Ideale per l'illuminazione di strade, vicoli, parcheggi, aree residenziali. Consigliato per pali di altezza di 6/8 m e interdistanza dei pali di 12/20 m.
 Conforme alle normative vigenti ed alle vigenti leggi contro l'inquinamento luminoso. La curvatura delle lenti permette un'apertura del fascio luminoso per un adeguato illuminamento del piano stradale. La struttura permette la dissipazione del calore dei led garantendo una durata di 40.000h e un basso decadimento del flusso.
Classe di isolamento I
Blocco Ottico IP65 - Vano cablaggio IP65

(GB)

Aluminium appliance for LED road lighting.
 Ideal for lighting small roads, alleys, car parks, and residential areas. Recommended for 6/8 m high poles, 12/20 m one from the other.
 Complying with Standard and laws in force against light pollution. The lens curving allows the light beam to open up to adequately illuminate the road surface. The finned structure permits the heat from the LED to dissipate, guaranteeing a duration of 40,000h and low light flow diminishing.
Class I insulation
Optical block IP65 - Wiring compartment IP65

STRADA LED 1

400 x 654 x h154mm

COLOUR	93W	LED	I	001	6000K	7892	40,28	10,5	555502.0101

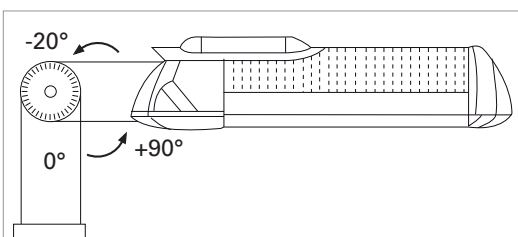

Codolo di rotazione per fissaggio armatura stradale con sistema testa palo.
 Rotary shank to fix street lamp at top of pole.

Descrizione	pcs	Codice
Description	pcs	Code
Codolo	001	703952.0101

Possibilità di richiedere anche il palo per fissare l'armatura.

Possibility of requesting pole for fitting.

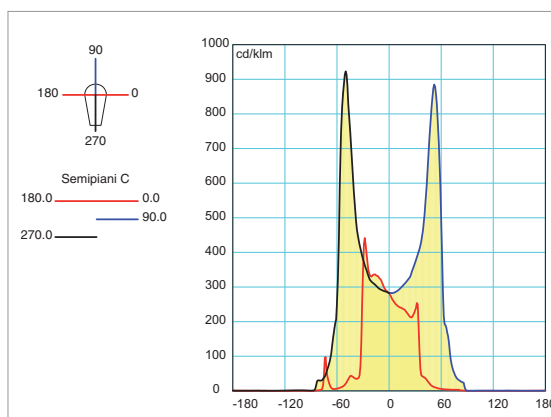
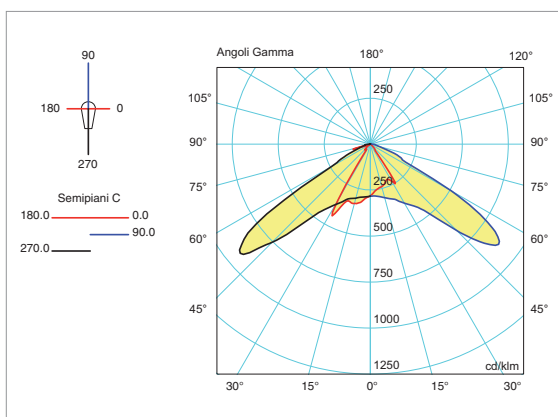

Corpo in Alluminio estruso 6060T5.

Testate in Alluminio pressofuso EN AB46100 verniciato a polvere termoindurenti poliesteri resistenti alla corrosione ed agli agenti atmosferici. Grigio RAL 9006.

Gruppo Ottico composto da Led di potenza CREE con apposita lente, montati su un dissipatore.

Pressacavo doppio in acciaio inox M12.

Lenti dedicate per adeguato illuminamento del manto stradale.

Led di potenza della cree 6000° K 95 lm/W ad alta luminosità.

Disponibili a richiesta (per quantità) anche temperature di colore differenti.

Alimentatore interno.

Tensione di funzionamento 86V / 250V, 50/60 Hz.

Viteria esterna in acciaio inox.

Fissaggio palo per mezzo di una piastra in alluminio estruso fissata al corpo dell'apparecchio tramite 4 viti in acciaio inox.

Casing in extruded aluminium 6060T5.

Die-cast aluminium **heads** EN AB46100 painted in polyester thermosetting powder resistant to corrosion and atmospheric agents. Grey RAL 9006.

Optical unit composed of CREE power LED with proper lens, mounted on a dissipator.

Double stainless steel **cable gland** M12.

Lens for adequate road surface illumination.

Cree 6000° K 95 lm/W bright power **LED**.

Different colour temperatures **available** upon request (for the amount).

Internal **power supply unit**.

Voltage: 86V / 250V, 50/60 Hz.

External screws in stainless steel.

Pole fastening by means of extruded aluminium plate fixed to appliance body by 4 stainless steel screws.

250V - 50 Hz

VANO CABLAGGIO
IP65



BLOCCO OTTICO
IP65

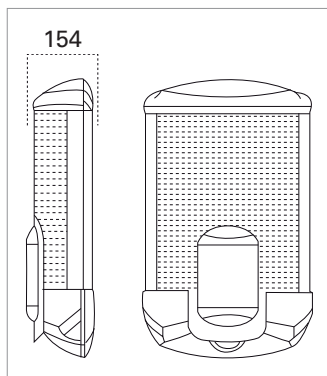
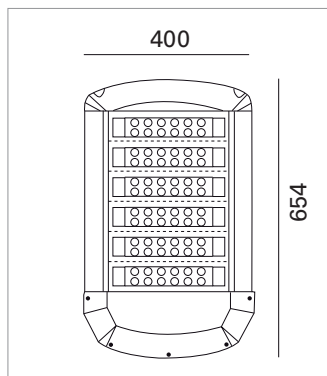

0,27 m²

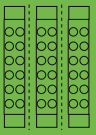

Sistema di fissaggio a palo tramite piastra in estruso di alluminio re 4 viti in acciaio inox. Pole fixing system by means of extruded aluminium plate with 4 stainless steel screws.

50.000h	5.000h
	
93W	E27 HLI-E 100W ELISSOIDALI

Comparazione di LED con una Lampade tradizionale.

