

# Apogon

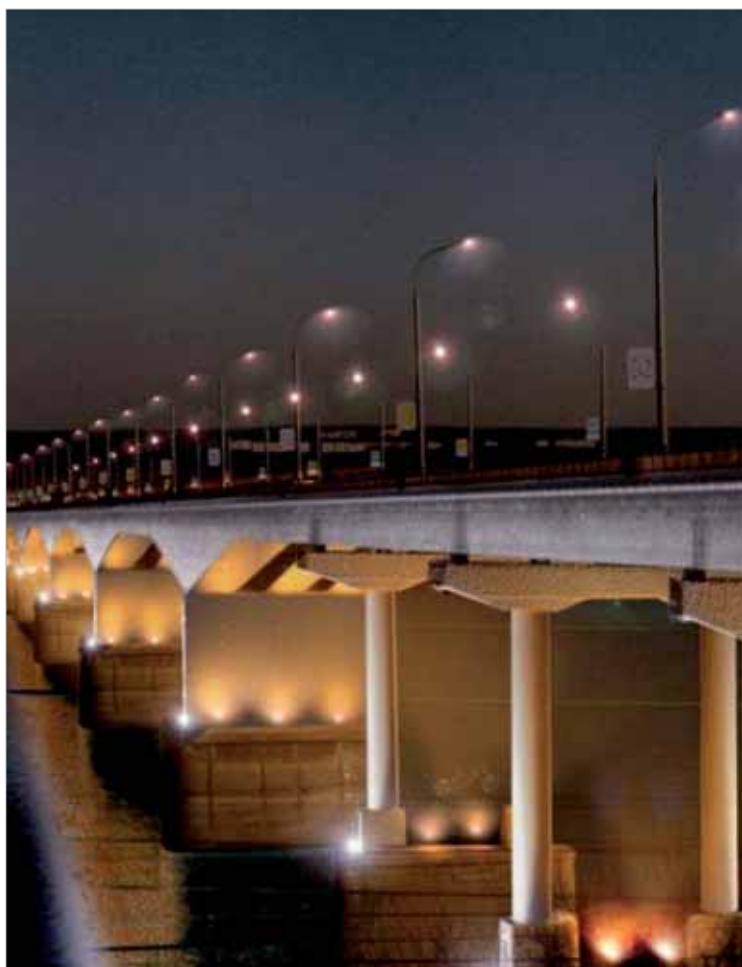

I

Apparecchio per illuminazione stradale con lampade a scarica fino a 150W, costruito interamente in pressofusione di alluminio. Di facile installazione e manutenzione, particolarmente indicato per l'illuminazione di sedi stradali ad elevata percorrenza in conformità alla norma UNI 10819 ed alle vigenti leggi in materia di inquinamento luminoso. Il sistema di regolazione (+/- 10 gradi) con il prodotto già in opera consente la massima precisione nell'installazione e nell'illuminazione della sede stradale.

**IP65 / Classe di isolamento I e II**

GB

Street-lighting fitting for discharge lamps up to 150W, entirely made from die cast aluminium. Easy to install and service, particularly fit for streets, boulevards, parks and outdoors in general. The light completely satisfies the UNI 10819 regulation and regional laws regarding the light pollution. The tilting system (+/- 10°) allows the highest beam direction accuracy during the installation with the fitting in operation.

**IP65 / Insulation class I or II**

**Corpo e copertura superiore:** in pressofusione di alluminio, verniciata in polveri termoindurenti resistenti alla corrosione e agli agenti atmosferici previo trattamento di fosfo-cromatazione.

**Sistema di chiusura:** clip di chiusura esterna in acciaio inox.

**Casing and upper cover:** die cast aluminium painted with thermo-hardened polyester powders after phospho-chromatation treatment; corrosion and weather resistant.

**Closing system:** stainless steel closing clip.

## APOGON

550 x 265 x h185mm

COLOUR	W	Light	W TOT	CLASSE ISOLAM	Icon 1	PALLETS	dm <sup>3</sup>	Kg	Icon 2	CNL
	70	NA-T	87	I	001	20	28	6,95	E27	702453.0139
	100	NA-T	114	I	001	20	28	7,20	E40	702454.0139
	150	NA-T	169	I	001	20	28	7,75	E40	702455.0139
	125	HLF	134	I	001	20	28	6,95	E27	702458.0140
	70	NA-T	87	II	001	20	28	6,95	E27	● 702471.0139
	100	NA-T	114	II	001	20	28	7,20	E40	● 702468.0139
	150	NA-T	169	II	001	20	28	7,75	E40	● 702469.0139
	125	HLF	134	II	001	20	28	6,95	E27	● 702470.0140

- ARTICOLI CHE, SE NON DISPONIBILI A MAGAZZINO, POSSONO RICHIEDERE FINO A 90 GIORNI PER LA CONSEGNA. FOR ARTICLES WHICH ARE NOT IN STOCK DELIVERY TIME CAN BE UP TO 90 DAYS.

**Blocco di fissaggio:** in pressofusione di alluminio verniciato con polveri termoindurenti resistenti alla corrosione e agli agenti atmosferici previo trattamento di fosfo-cromatazione. Scomponibile dalla struttura principale (inserimento ad incastro) consente il montaggio "testapalo" o "a sbraccio" per pali Ø = 60 mm. **Riflettore:** di tipo cut-off in alluminio purissimo, stampato ed ossidato anodicamente.

**Vetro di chiusura:** spessore 4 mm, piano temperato, resistente agli urti ed agli shock termici, montato sul corpo inferiore portante con guarnizione interposta. **Guarnizione:** in gomma siliconica. **Viteria:** acciaio inox. **Pressacavo:** n° 1 pressacavo in dotazione M25 antistrappo Nylon. **Morsetti di alimentazione:** morsetti a tre poli in poliammide di sezione 4 mm<sup>2</sup> per apparecchi in classe di isolamento I. Sezionatore bipolare in materiale termoplastico con sezione dei morsetti di 4 mm<sup>2</sup> per apparecchi in classe di isolamento II. **Piastra:** asportabile in tecnopolimero autoestinguente V0. **Cavi:** in silicone sezione 1,5 mm<sup>2</sup> con calza di protezione in fibra di vetro. **Portalamпада:** E27 e E40 ceramico.

**Join block:** die cast aluminium painted with thermo-hardened polyester powder after phospho-chromatation treatment. Detachable from the main casing it allows "head" or "bracket" mounting on Ø = 60 mm poles.

**Reflector:** cut-off type, in finest aluminium, oxidized and polished. Adjustable lamp focus for an optimal use of the optics.

**Closing glass:** 4 mm flat tempered glass, blow and thermic shock resistant, mounted on the lower casing with a pre-shaped gasket. Gasket: silicon rubber. **Screws:** stainless steel.

**Cable-gland:** M25 IP 68 Nylon anti-tear cable-gland.

**Connecting terminal:** 4 mm<sup>2</sup> section polyamid tripolar terminals for class I insulation lights; 4 mm<sup>2</sup> section thermoplastic bipolar cut-off switch for class II insulation lights.

**Gear tray:** auto-extinguishing V0 tecnopolimer; removable.

**Cables:** 1.5 mm<sup>2</sup> silicon cables with fiber-glass braid sleeve.

**Lamp-holder:** E27 and E40 ceramic.

230V - 50 Hz    IP65                           

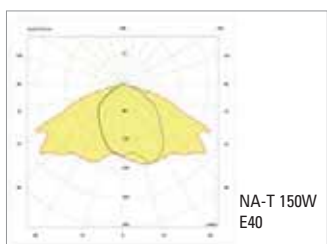
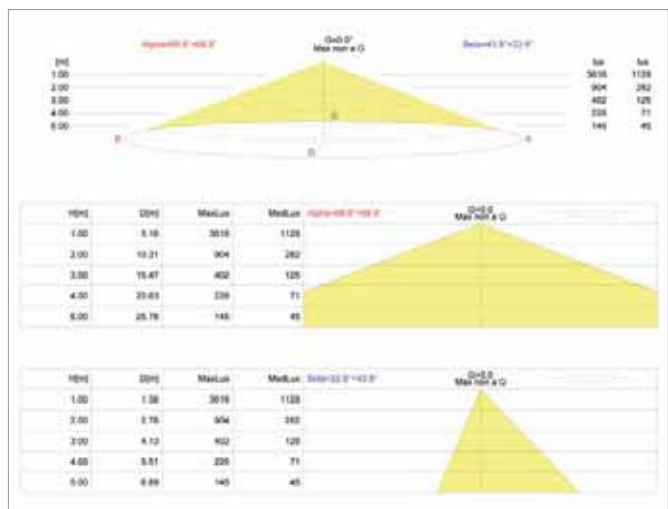
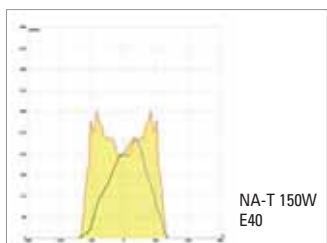
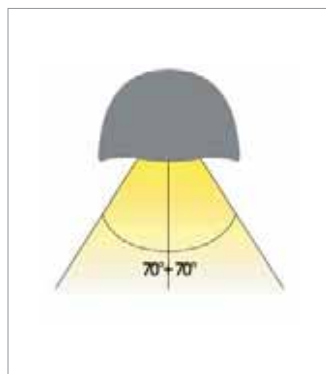
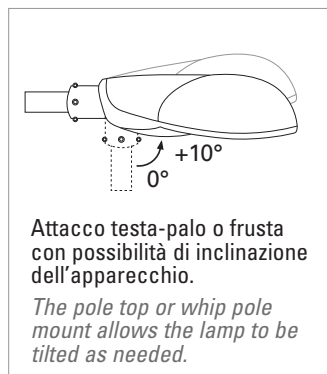
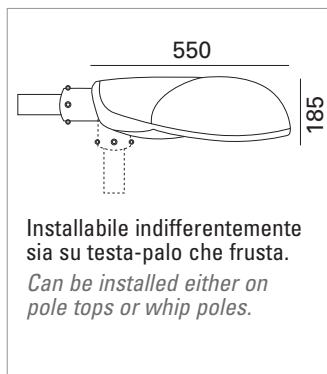
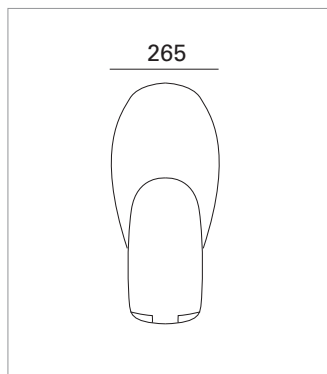
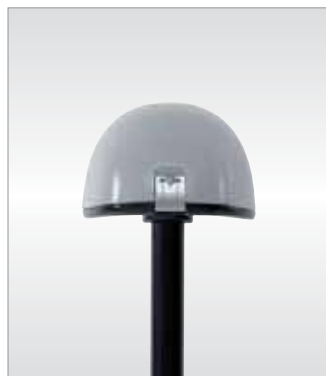
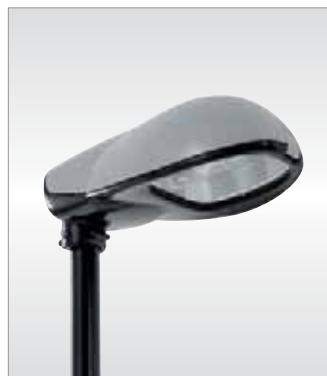

Possibilità di operare in massima sicurezza grazie al nuovo sistema di innesto a molla.

Maximum safety thanks to the new spring-mount system.

**ACCESSORI / ACCESSORIES**



**Descrizione**  
**Description**

*Adattatore palo - Pole adapter  $\varnothing$  80/60 mm esterno*  
*Da fissare su pali  $\varnothing$  min. 40 mm - To fix on pole  $\varnothing$  min. 40 mm*



001

**Codice**  
**Code**

703950.0101

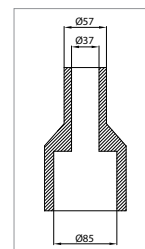

*Braccio a parete - Wall Bracket*

001

702196.0101



Illuminazione pubblica - Public lighting

I

**PROPRIETÀ**

**FIG. 1** Attacco palo universale per installazioni a sbraccio e testa palo  $\varnothing = 60$  mm costituito da un blocco di fissaggio in pressofusione di alluminio verniciato con polveri poliestere previo trattamento di fosfo-cromatazione. Scomponibile dalla struttura principale (inserimento ad incastro). Consente il montaggio "testa-palo" o "a sbraccio".

**FIG. 2-3** È possibile inclinare l'apparecchio di  $\pm 10^\circ$  semplicemente avvitando o svitando una vite posizionata sulla base del prodotto anche quando l'apparecchio è già installato (brevetto Leuci).

**FIG. 4** Le operazioni di normale manutenzione sono effettuabili senza l'uso di utensili. Sganciando la clip in acciaio inox e ruotando il coperchio attorno ad una cerniera, si permette l'accesso alla piastra ausiliari ed alla lampada.

GB

**MAIN FEATURES**

**Pict. 1** Universal pole join for top or side entry  $\varnothing = 60$  mm by a die cast block aluminium painted with polyester powder after phospho-chromatation treatment, delivered as part of the fitting and detachable from the main structure.

**Pict. 2-3** Possibility to tilt the light  $\pm 10^\circ$  by simply turning a screw placed on the join block, even when the fixture has already been installed (Leuci patent).

**Pict. 4** Servicing with no use of tools. By releasing the stainless steel clip and lifting the hinged cover, the gear tray and the lamp are accessible.



Pressacavo  
M25 x 1  
in plastica.

M25 x 1 plastic  
cable-gland.



Attacco frusta.  
Whip poles.

**PROGETTO / PROJECT**

**STREET LIGHTING**

