

# TN 3

C

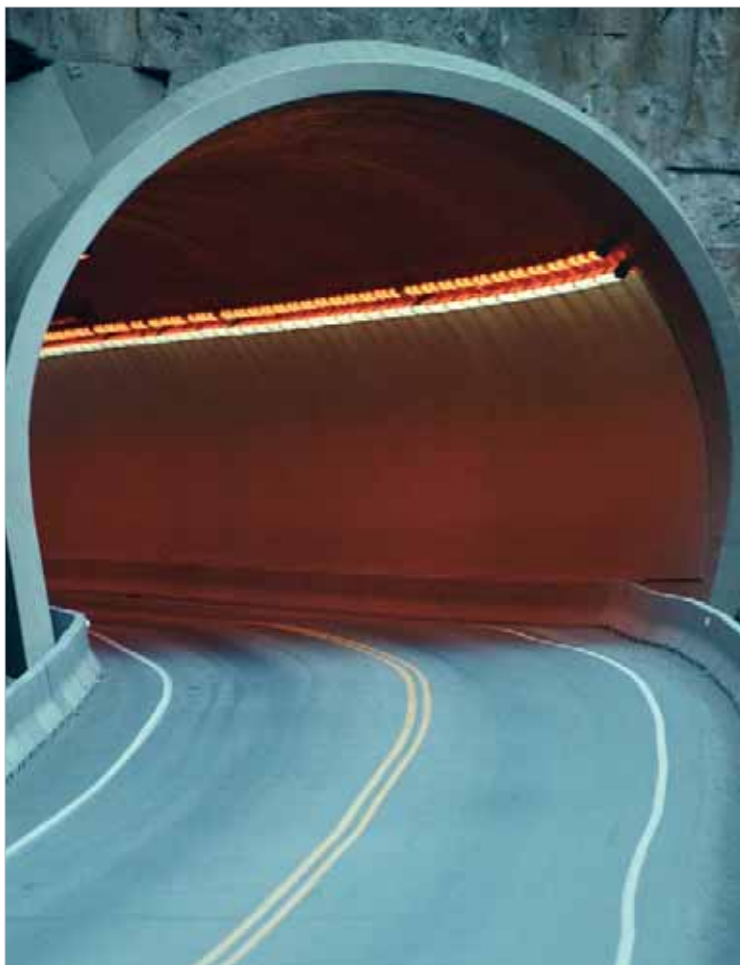

I

Corpo illuminante per galleria stradale, a tenuta stagna, con ottica simmetrica ed asimmetrica. Le soluzioni costruttive adottate agevolano l'operatore nelle operazioni di installazione e manutenzione, riducendo al minimo i rischi e gli oneri di intervento.

Idoneo per lampade a scarica a vapori di sodio ad alta pressione tubolari, bassa pressione tubolari e ioduri metallici da 70W a 400W.

**IP65 / Classe di isolamento II**

GB

Lighting unit, waterproof and with symmetrical and asymmetrical optics, for road tunnels.

The adopted constructional solutions make installation and maintenance operations simple and fast, reducing risks and costs of intervention.

Suitable for tubular high pressure sodium discharge lamps, tubular low pressure and metal halide lamps from 70W to 400W.

**IP65 / Insulation class II**

## TN 3 SM

265 x 700 x h150mm



COLOUR	W	Light bulb icon	W TOT	CLASSE ISOLAM	Stack icon	dm <sup>3</sup>	Kg	Light fixture icon	CNL
	150	NA-T	169	II	001	39	9,10	E40	● 704470.0139
	250	NA-T	270	II	001	39	10,20	E40	● 704473.0139
	400	NA-T	438	II	001	39	11,00	E40	● 704474.0139

## TN 3 AS

265 x 700 x h150mm



COLOUR	W	Light bulb icon	W TOT	CLASSE ISOLAM	Stack icon	dm <sup>3</sup>	Kg	Light fixture icon	CNL
	150	NA-T	169	II	001	39	9,10	E40	● 704462.0139
	250	NA-T	270	II	001	39	10,20	E40	● 704463.0139
	400	NA-T	438	II	001	39	11,00	E40	● 704464.0139

● ARTICOLI CHE, SE NON DISPONIBILI A MAGAZZINO, POSSONO RICHIEDERE FINO A 90 GIORNI PER LA CONSEGNA.  
FOR ARTICLES WHICH ARE NOT IN STOCK DELIVERY TIME CAN BE UP TO 90 DAYS.

**Corpo:** estruso in lega leggera di alluminio, ossidato, con scanalature sul dorso per ospitare gli elementi di fissaggio alle staffe di sospensione.  
**Testate laterali di chiusura:** in pressofusione di alluminio verniciate con polveri poliestere. **Vetro:** temprato, spessore 5mm.  
**Riflettore:** in alluminio martellato (99.85%) brillantato e ossidato anodicamente, incernierato alla piastra cablaggio, studiato in modo da garantire un alto rendimento e un'efficace controllo dell'emissione luminosa. **Portalamпада:** E40 Rhyton termoplastico, fissato alla piastra portacablaggio.  
**Viteria:** esterna inox. **Cavi:** con conduttore flessibile di rame avente sezione 1.5 mm<sup>2</sup> isolato a 5000V in gomma siliconica e rivestito con guaina di fibra di vetro per temperature fino a 350°C.  
**Morsettiere di alimentazione:** Sezionatore bipolare in materiale termoplastico con sezione dei morsetti di 4 mm<sup>2</sup> per apparecchi in classe di isolamento II. **Pressacavo** posto lateralmente su una testata per l'ingresso diretto del cavo di alimentazione, possibilità di utilizzare pressacavi sia M20 che M25 IP65.

**Unit:** extruded light aluminium alloy, oxidized, with grooves on the rear section to accommodate mounting brackets.  
**Side closures:** in die-cast aluminium, coated with polyester powder paint. **Glass:** tempered, 5 mm thick.  
**Reflector:** in hammered aluminium (99.85%), anodized with mirror finish, hinged to the wiring plate, designed to guarantee high efficiency and a high degree of light emission control. **Lamp-holder:** E40 Rhyton thermoplastic, fixed to the wiring plate. **Screws:** external stainless steel.  
**Cables:** with 1.5 mm<sup>2</sup> cross-section flexible copper conductor, insulated to 5000V in silicone rubber and coated with fiber glass braid sleeve for temperatures up to 350°C.  
**Terminal block:** Bipolar thermoplastic cut-off switch with 4 mm<sup>2</sup> cross-section of terminals for class II insulation.  
**Cable gland:** positioned to the side of one of the headers for direct entry of line wires; either M20 or M25 IP65 cable gland can be used.

230V - 50 Hz    IP65                              

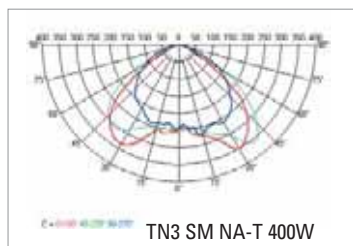
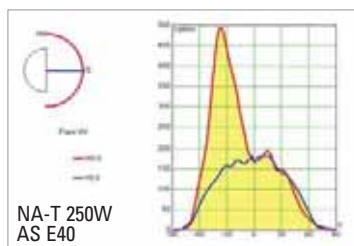
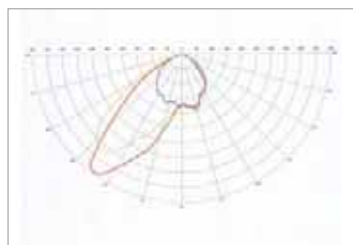
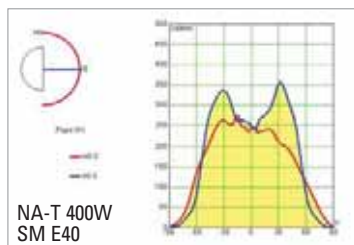
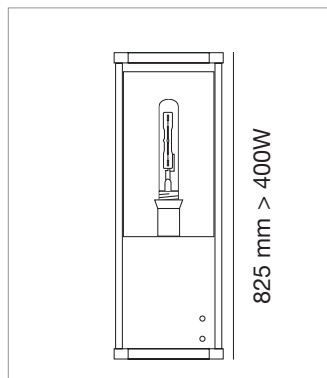
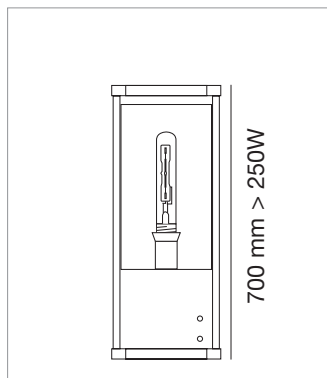
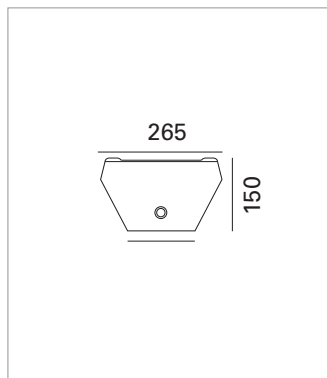



### I PROPRIETÀ

Vetro frontale temprato incernierato in testata da due profili in alluminio pressofuso uniti al corpo in maniera da renderli impermeabili in fase di manutenzione. La tenuta stagna viene garantita tramite guarnizioni in silicone espanso adesivo. Apertura dell'apparecchio di estrema facilità pratica mediante due sole cerniere impermeabili in alluminio estruso poste longitudinalmente al corpo, che garantiscono una tenuta omogenea su tutta la lunghezza del diffusore (brevetto depositato).

Piastra portacablaggio completamente estraibile senza l'ausilio di utensili, e possibilità, in fase di manutenzione, di lasciarla appesa al corpo.

### GB MAIN FEATURES

Tempered front glass, hinged with two die-cast aluminium frames join to the casing in order to avoid falls during maintenance operations. The water tightness is guaranteed by gaskets in adhesive microcellular silicone. Opening of the fitting is achieved through two fall-protected extruded aluminium hinges longitudinally fixed to the casing allowing an homogeneous tightness along the total length of the diffuser; extremely practical and simple (Patent pending).

Fully extractable wiring plate without the need of tools, with the option of leaving the plate suspended below the unit during maintenance operations.



## PROGETTO / PROJECT

### TUNNEL LIGHTING - UNDERPASSES LIGHTING

